

**FUNDAMENTALS OF PLC
PROGRAMMING: SYSTEM DESIGN
NOTES AND LAB PROJECT (No.#4)**

INTRODUCTION:

In developing Industrial Automation Systems, Functional Requirements must be available for the Electromechanical Technician to install and maintain the equipment. Therefore, all supporting documentation must be ready at the day of installation. Occasionally, the Electromechanical Technician may be called to aid the Automation Engineer by creating the installation documentation. To aid in the configuration of the PLC based machine, the I/O module & relay ladder wiring diagrams, system block diagrams, and ladder logic programs are the key supporting documents needed for equipment installation.

INTRODUCTION...:

This laboratory assignment will provide skills in generating the documentation previously listed. Also, the fundamentals of programming the PLC will be practice using the Handheld Terminal (HHT).

MACHINE REQUIREMENTS:

A Mill Table See *Figure 1* has been purchased by the Prototype shop to assist in the development of wireless light controllers for Christmas Lights. The Mill Table functions as follows:

1. An AC electric motor to be used for moving the parts table back and forth (NOTE: The initial prototype will only allow the table to travel forward)
2. The table will be control by either a **Feed** or **Jog** Button.
3. While operating the table, both the **Emergency Button** and the **End of Travel Limit Switch** will be ON.

Figure 1. Prototype Mill Table

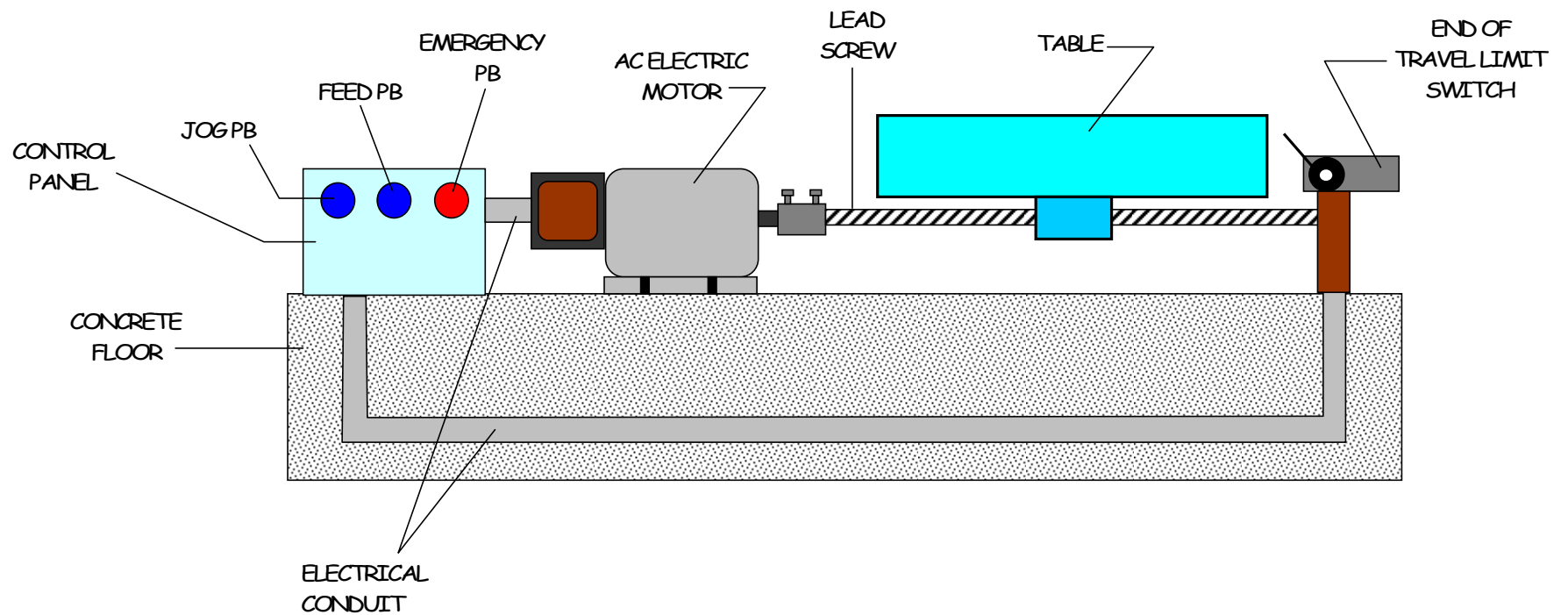

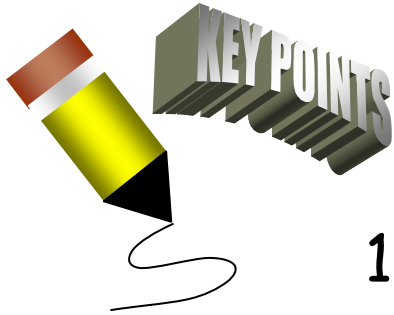

DOCUMENTS TO BE CREATED

1. Relay Ladder Wiring Diagram
2. I/O Module Wiring Diagram
3. Logic Circuit Diagram
4. Truth Table and Boolean Expression
5. System Block Diagram
6. Ladder Logic Diagram

Figure 2. Relay Ladder Wiring Diagram

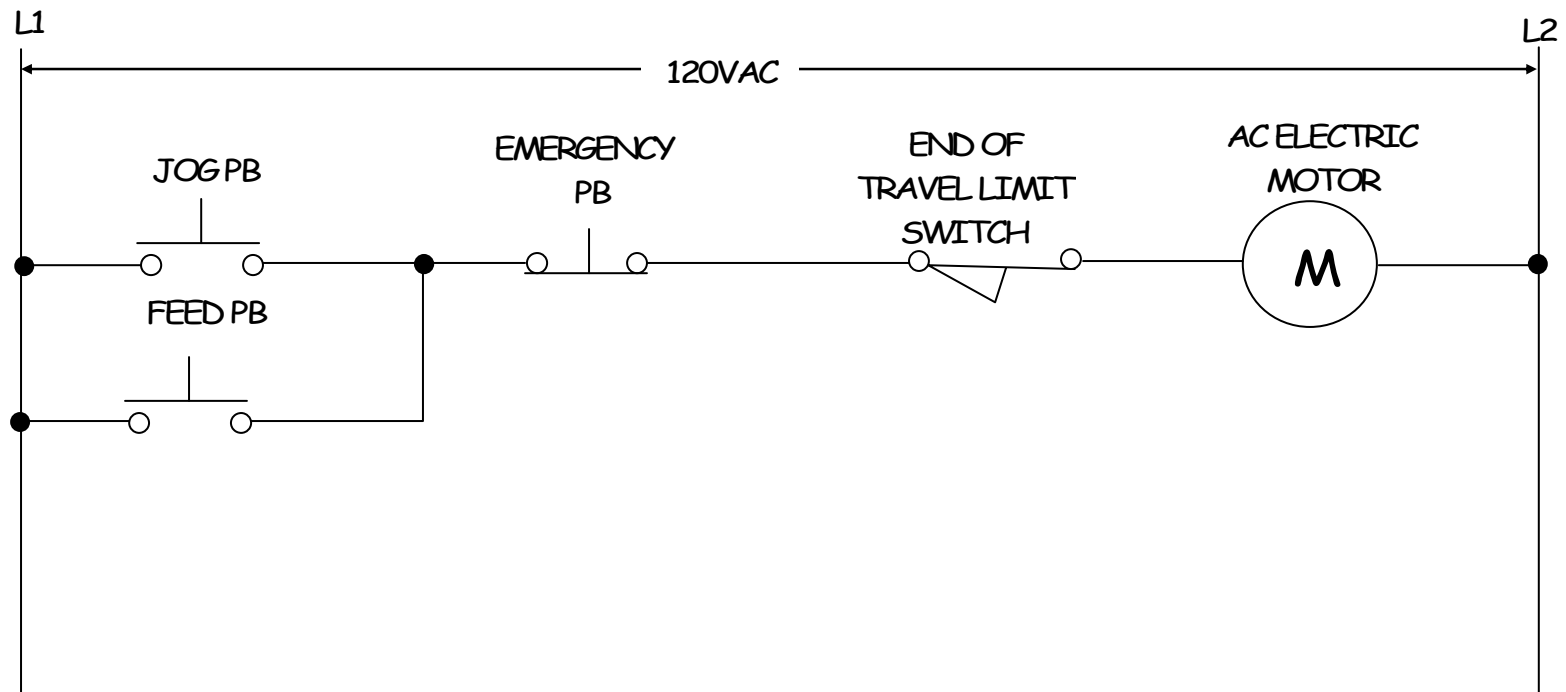

Figure 3. I/O Module Wiring Diagram

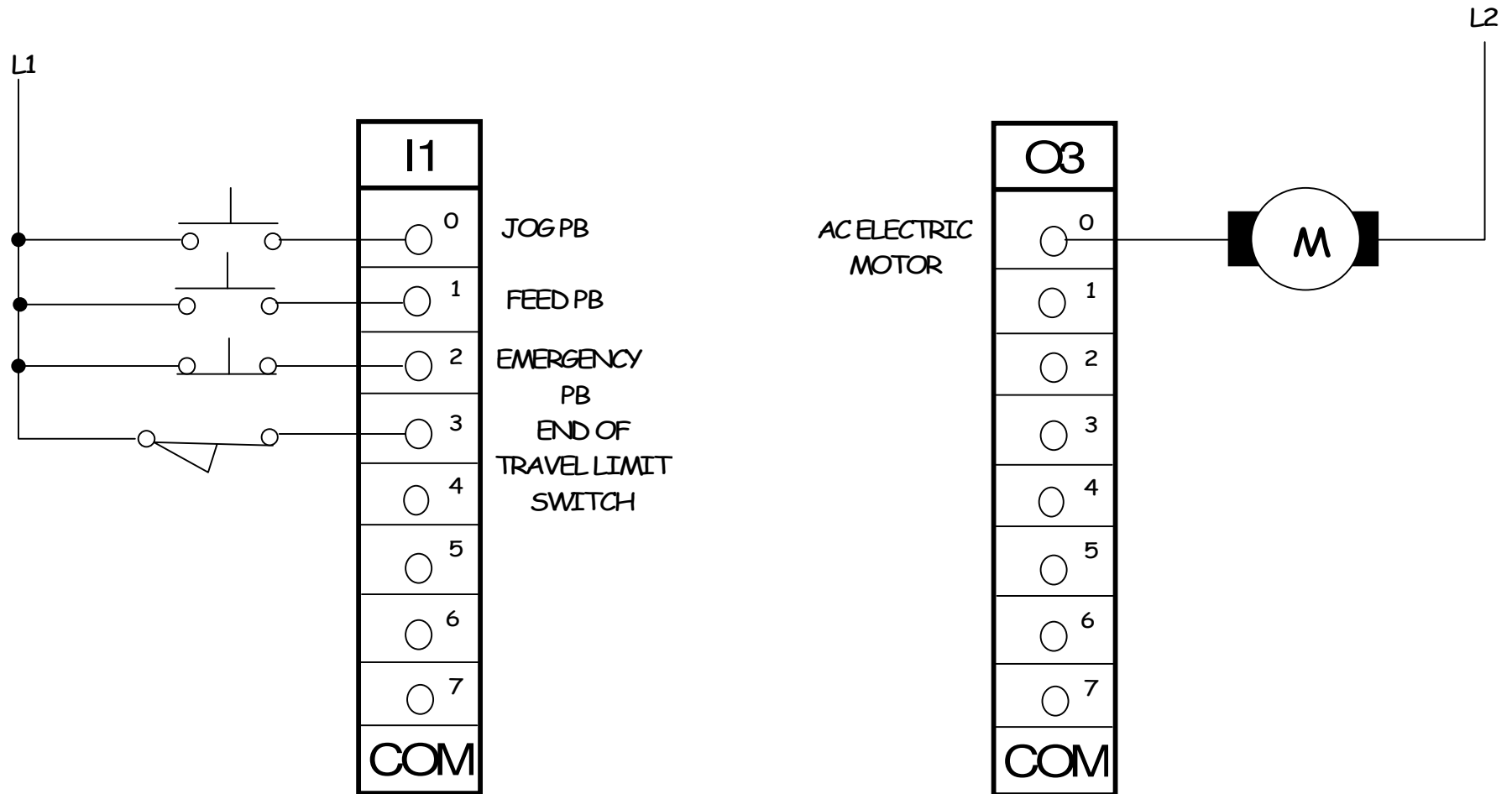

Figure 4. Logic Circuit Diagram

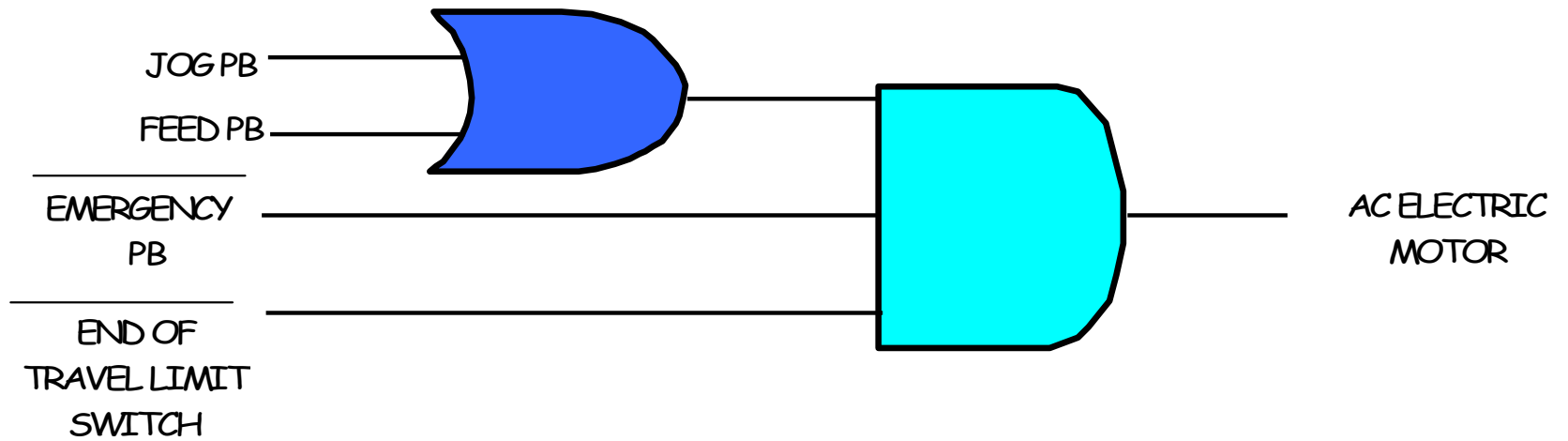

Figure 5. Truth Table and Boolean Expression

AC ELECTRIC MOTOR = M

BOOLEAN EXPRESSION:

JOG PB = J

$$M = (J + F)(\overline{EPB} * \overline{EOT})$$

FEED PB = F

EMERGENCY = EPB
PB

END OF = EOT
TRAVEL LIMIT
SWITCH

Figure 5. Truth Table and Boolean Expression...

INPUTS				OUTPUT
J	F	\overline{EPB}	\overline{EOT}	M
0	0	0	0	0
0	0	0	1	0
0	0	1	0	0
0	0	1	1	0
0	1	0	1	0
0	1	1	0	0
0	1	1	1	1
1	0	0	0	0
1	0	0	1	0
1	0	1	0	0
1	0	1	1	1
1	1	0	0	0
1	1	1	0	0
1	1	1	1	1

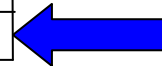
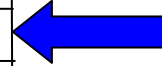
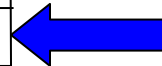

AC ELECTRIC MOTOR = ON

Figure 6. System Block Diagram or System Model

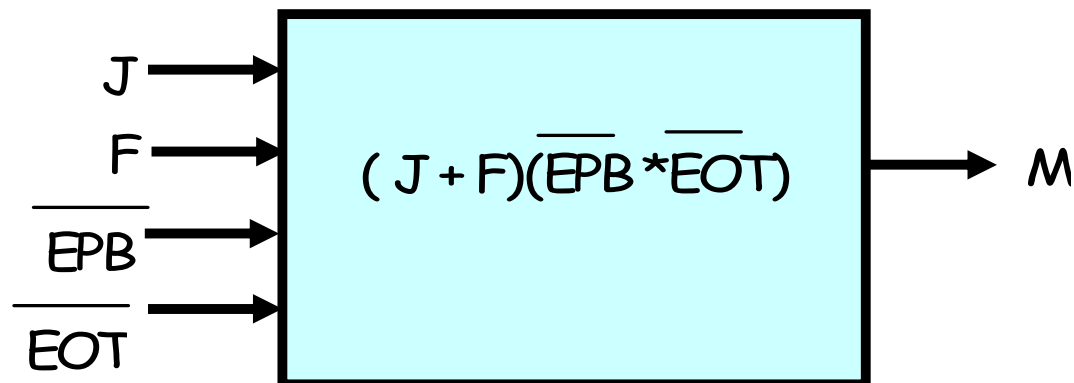

SYSTEM BLOCK DIAGRAM
OR
SYSTEM MODEL

Figure 7. Ladder Logic Diagram

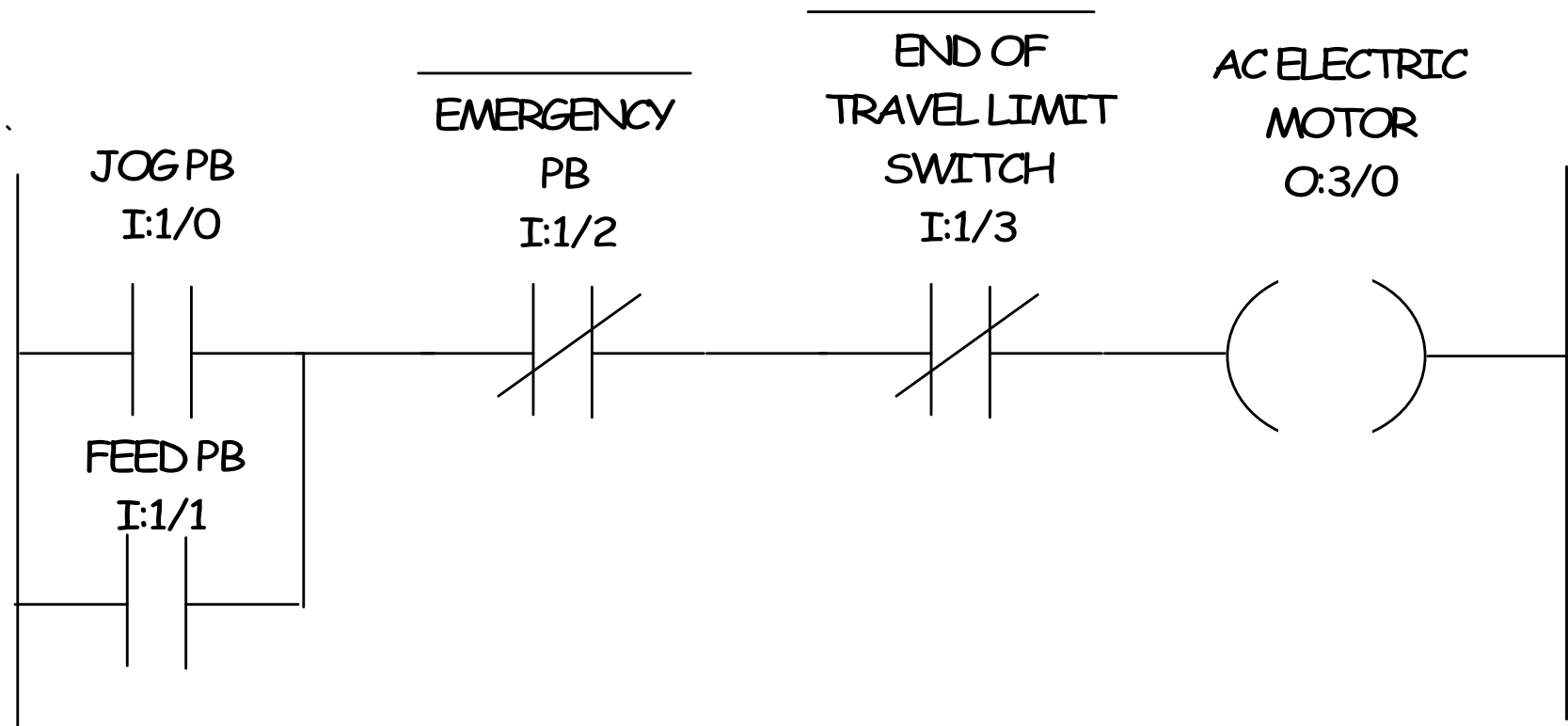

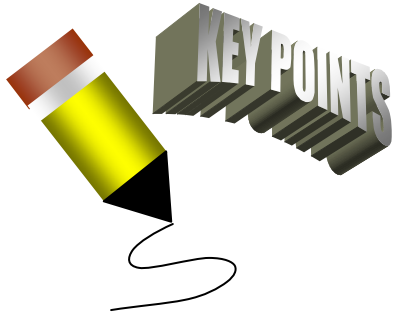

LAB 4 ASSIGNMENT: MILL TABLE MACHINE APPLICATION

Generate the following Engineering Documentation

1. Multisim Logic Circuit. (Demo Circuit to Instructor)
2. PLC Programming Exercise
 - a) Create I/O Module Wiring Diagram
 - b) Create Ladder Logic Program
 - c) Program and test target PLC with document created in step 2.c (Demo Program to Instructor)

Instructor's Initials_____