

ET285 DIGITAL ELECTRONICS II
PRELAB 1: DEBOUNCING DIGITAL SWITCH
(A Practical Application for a LATCH)

INTRODUCTION

A latch is a type of temporary storage device that has 2 stable states (bistable) and is normally placed in a category separate from FF. Latches are similar to FFs because they are bistable devices that can reside in either of 2 states using a feedback arrangement, in which the outputs are connected back to the opposite inputs. The main difference between latches and FFs is in the method used for changing their states.

ASSIGNMENT

1. Read section 8-1 "LATCHES" in the textbook. The practical application example is on page 397.
2. Build the circuit shown below on your breadboard.
3. To test the circuit prior to the Lab Session (3/24). A 6volt battery along with a series Si. Diode (1N4001) can be used to provide a safe operating voltage of +5.3VDC for the digital circuit.
4. Toggle the switch and observe the operation of the LEDs.(TESTING)
5. Keep this circuit built to be used in next week's lab (3/24).(DEMO)

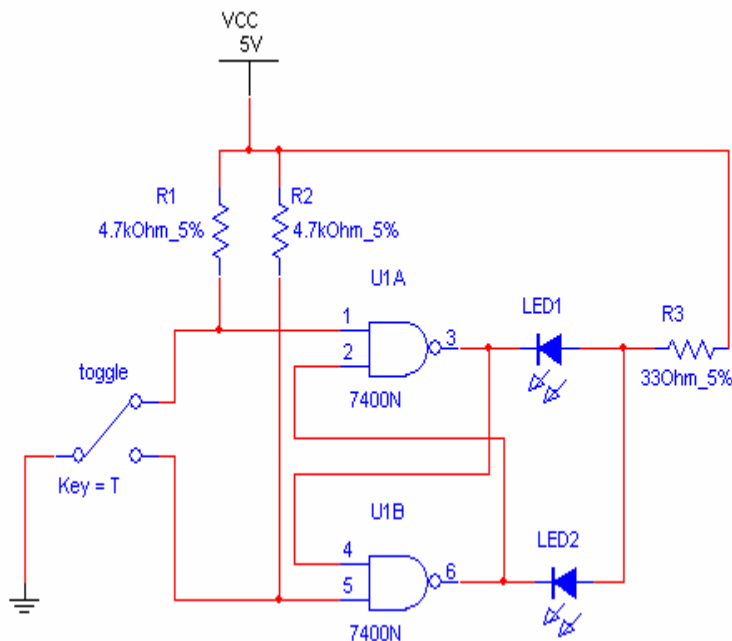

Figure 1. Debouncing Digital Switch